

# Specification

MODEL

**1Li-ion18650C**

Nominal Capacity

**2600mAh**

Registered	Checked	Approved
<b>2016.10.21</b>		<b>2016.10.21</b>

1. MODIFIED LIST.....	1
2 .Scope .....	3
3. Initial Dimension .....	4
4. Battery pack Specifications .....	5
5.Cell Dimensions .....	5
6. Cell Specifications .....	6
7.Cell General Performance .....	7
8.Cell Environment Performance .....	7
9.Cell Safe Characteristic .....	8
10.Protective circuits .....	8
11. CAUTIONS IN USE .....	9
12. Battery operation instruction .....	9
13. Period of Warranty .....	10
14. Other The Chemical Reaction .....	10
15.Note: .....	11

## 1. MODIFIED LIST



caution of the Li- ion Cylindrical rechargeable battery .

### 3. Initial Dimension

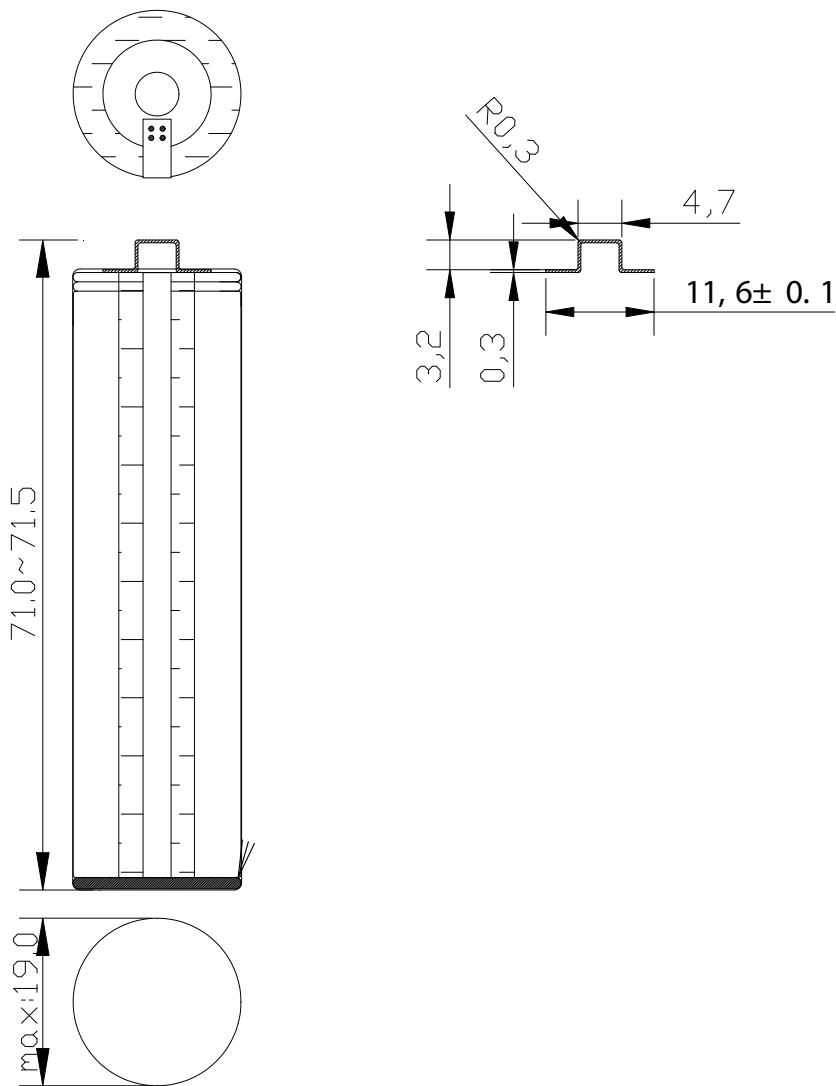

#### 4. Battery pack Specifications

NO.	Item	Specifications	
4.1	Typical Capacity	2600mAh @ 0.2C Discharge (0.2C )	
4.2	Nominal voltage	3.70V	
4.3	Charge	Max input voltage	10V ± 0.05
		Max Charge voltage	4.20V ± 0.05
		Standard charge current	520mA
		Max Charge current	2600mA
4.4	Discharge	Min Discharge voltage	2.8V ± 0.05(PCB End-of-charge Voltage )
		Fast Discharge current	2600mA
		Max continuous discharge current	3000mA
4.5	Initial Impedance	Max: 160m	
4.6	Weight	Approx( ): 49 ± 2g	
4.7	Operating temperature	Charging( ): 0°C~45°C Discharging( ): -20°C~60°C	
4.8	Storage temperature	-5°C~35°C	
4.9	Storage Humidity	≤75% RH	
4.10	Appearance	Without scratch, distortion, contamination and leakage	
4.11	Standard environmental condition	Temperature : 25 ± 2°C Humidity : 45-75%RH Atmospheric Pressure : 86-106 KPA	

#### 5. Cell Dimensions

Max(H) 65.5mm	Max (D)18.5 (mm)
---------------	------------------

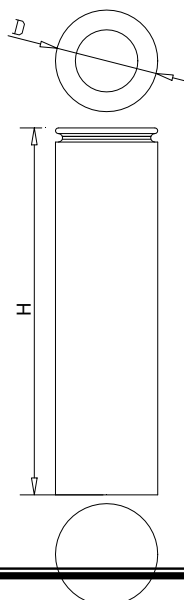

## 6.Cell Specifications

NO.	Item	Specifications				
6.1	Typical Capacity	2600mAh @ 0.2C Discharge (0.2C )				
	Minimum capacity	2580mAh @ 0.2C Discharge (0.2C )				
6.2	Nominal voltage	3.70V				
6.3	Standard Charge	CC/CV,0.2C5A,4.20V				
6.4	Standard Discharge	CC,0.2C5A, 3.00V				
6.5	End-of-charge Voltage	4.20V±0.1V				
6.6	End-of-charge Current	0.02C5A (At CV mode)				
6.7	End-of-discharge Voltage	3.00 V				
6.8	Charging Time	8.0hours (standard charge)				
6.9	Quick Charge Current	2600mA (1.0C5rate) 1C				
5.10	Quick Discharge Current	5200mA (2.0C5rate) 2C				
6.11	Max Discharge Current	7800mA (3.0C5rate) 3C				
6.12	Initial Impedance	Max: 55m				
6.13	Weight	Approx : 46.5±2g				
6.14	Operating temperature	Charging 0°C~45°C Discharging -20°C~60°C				
6.15	Storage temperature	-5°C~35°C				
6.16	Storage Humidity	≤75% RH				
6.17	Appearance	Without scratch, distortion, contamination and leakage				
6.18	Standard environmental condition	Temperature : 25±2°C Humidity : 45-75%RH Atmospheric Pressure : 86-106 KPA				
6.19	Temperature Dependence of Discharge Capacity @ 0.2C Discharge (0.2C )					
Charge temperature		Discharge temperature				
25°C		-10°C	0°C	15°C	25°C	40°C
Relative Capacity		50%	80%	90%	100%	100%

The discharge capacity and rate only applies to single electrical cores

## 7 Cell General Performance

No.	Item	Test Methods and Condition	Criteria
7.1	0.2C Capacity	After standard charging, rest battery for 10min, then discharging at 0.2C to voltage 3.0V, recording the discharging time.	$\geq 300$ min
7.2	Cycle Life	Constant current 0.5C charge to 4.2V, then constant voltage charge to current declines to 0.01C, rest 10min , constant current 0.5C discharge to 3.0V , rest 10min. Repeat above steps till continuously discharging capacity Higher than 80% of the Initial Capacities of the Cells	$\geq 300$ times
7.3	Capability of keeping electricity	$20 \pm 5^{\circ}\text{C}$ , After standard charging, rest the battery 28days, discharging at 0.2C to voltage 3.0V, recording the discharging time.	$\geq 240$ min

## 8 Cell Environment Performance

No.	Item	Test Methods and Condition	Criteria
8.1	Discharge at high temperature	After standard charging, rest the cells 4h at $60 \pm 2^{\circ}\text{C}$ , then discharging at 1C to voltage 3.0V, recording the discharging time.	$\geq 54$ min
8.2	Discharge at low temperature	After standard charging, rest the cells for 16h at $-20 \pm 2^{\circ}\text{C}$ , then discharging at 0.2C to voltage 3.0V, recording the discharging time.	$\geq 210$ min
8.3	Thermal shock	Put the cells in the oven. The temperature of the oven is to be raised at $5 \pm 2^{\circ}\text{C}$ per minute to a temperature of $130 \pm 2^{\circ}\text{C}$ and remains 30 minutes.	No fire, no smoke

## 9 Cell Safe Characteristic

No.	Item	Test Methods and Condition	Criteria
9.1	Over charge testing	At $23 \pm 5^\circ\text{C}$ , charging cells with constant current 2C to voltage 5.0V, Stop test till cells temperature $10^\circ\text{C}$ lower than max temperature.	No smoke or fire
9.2	Over discharge testing	At $23 \pm 5^\circ\text{C}$ , According to the requirements of standard charge, the cells will be discharge to cut-off voltage, then connect with external load of 30 ohm for 24 hours.	No fire, no smoke, no leakage.
9.3	Short-circuit testing	At $23 \pm 5^\circ\text{C}$ , After standard charging, connect cells anode and cathode by wire which impedance less than $80 \pm 20\text{m}\Omega$ , keep 6h.	No smoke or fire

※ Above testing of safe characteristic must be with protective equipment

## 10. Protective circuits

### 10.1 PCM Standard

No	Item	Condition	Specification
1	input Voltage	input Voltage B+ to B-	-0.3~+12V
2	Overcharge	Detection voltage	4.28±0.05V
3		Release voltage	4.08±0.05V
4		Detection delay time	80~200mS
5		Detection voltage	2.8±0.05V
6	Over discharge	Release voltage	2.8±0.05V
7		Detection delay time	115~173mS
8		Over current	5~9A
9	Over discharge current	delay time	MAX 20mS
10		Short detection delay time	MAX380us
11		Release Conditions	'Cut off load
12	Normal current consumption	Normal current consumption of PCM	Max 7.00uA
13	0V charger	allowed 0V change	YES
14	Suggest working conditions	max continuous charge/discharge current	3.0A
15		'suggest working temperature	-20℃~60℃
16	'IR resistance	IR of PCM	≤65.00 mΩ

## 11. CAUTIONS IN USE

To ensure proper use of the battery please read the manual carefully before using it. Handling

- Do not expose to, dispose of the battery in fire.
- Do not put the battery in a charger or equipment with wrong terminals connected.
- Avoid shorting the battery
- Avoid excessive physical shock or vibration.
- Do not disassemble or deform the battery.
- Do not immerse in water.
- Do not use the battery mixed with other different make, type, or model batteries.
- Keep out of the reach of children.

- Battery must be charged in appropriate charger only.
- Never use a modified or damaged charger.
- Do not leave battery in charger over 24 hours.
- Store the battery in a cool, dry and well-ventilated area.
- Regulations vary for different countries. Dispose of in accordance with local regulations.

## **12. Battery operation instruction**

### **12.1 Charging**

Charging current: Cannot surpass the biggest charging current which in this specification book stipulated.

Charging voltage: Does not have to surpass the highest amount which in this specification book stipulated to decide the voltage.

Charge temperature : The battery must carry on the charge in the ambient temperature scope which this specification book stipulated.

Uses the constant electric current and the constant voltage way charge, the prohibition reverse charges. If the battery positive electrode and the cathode meet instead, can damage the battery.

### **12.2 Discharging current**

The discharging current does not have to surpass this specification book stipulation the biggest discharging current, the oversized electric current electric discharge can cause the battery capacity play to reduce and to cause the battery heat.

### **12.3 discharge temperature**

The battery discharge must carry on in the ambient temperature scope which this specification book stipulated

### **12.4 Over-discharges**

After the short time excessively discharges charges immediately cannot affect the use, but the long time excessively discharges can cause the battery the performance, battery function losing. The battery long-term has not used, has the possibility to be able to be at because of its automatic flashover characteristic certain excessively discharges the condition, for prevented excessively discharges the occurrence, the battery should maintain the certain electric quantity.

### **10.5 Storing the Batteries**

The battery should store in the product specification book stipulation temperature range. If has surpasses above

for six months the long time storage, suggested you should carry on additional charge to the battery.

### **13. Period of Warranty**

The period of warranty is one year from the date of shipment. guarantees to give a replacement in case of cells with defects proven due to manufacturing process instead of the customers abuse and misuse.

### **14. Other The Chemical Reaction**

Because batteries utilize a chemical reaction, battery performance will deteriorate over time even if stored for a long period of time without being used. In addition, if the various usage conditions such as charge, discharge, ambient temperature, etc. are not maintained within the specified ranges the life expectancy of the battery may be shortened or the device in which the battery is used may be damaged by electrolyte leakage. If the batteries cannot maintain a charge for long periods of time, even when they are charged correctly, this may indicate it is time to change the battery.

### **15.Note:**

Any other items which are not covered in this specification shall be agreed by both parties.